

# AZIONAMENTO PORTELLONI FLAP'S DEVICES



**PRIMA**  
INDUSTRIES

17H

**Tutti i prodotti contenuti in questa sezione rispondono alle seguenti normative:**

#### **REGOLAMENTO 107/06**

(disposizioni speciali da applicare ai veicoli adibiti al trasporto passeggeri aventi più di otto posti a sedere oltre al sedile del conducente e recante modifica alle direttive 70/156/CEE, 97/27/CE e 2001/85/CE)

#### **UN ECE R118 e FMVSS302**

(velocità e metodica di combustione dei materiali utilizzati per la costruzione degli interni di veicoli a motore)

#### **DIRETTIVA 2000/53/CE ( e successivi emendamenti: 2008/33/CE)**

(messa al bando dei metalli pesanti piombo, cadmio, mercurio e cromo esavalente)

#### **DIRETTIVA 2002/95/CE - (ROHS)**

(messa al bando dei metalli pesanti, del polibrominato bifenile - PBB e del pentabromodifenil etere - PBDE)

#### **DIRETTIVA 1907/2006/CE - (REACH)**

#### **DIRETTIVA 2005/20/CE - (e successivi emendamenti)**

(bando delle sostanze pericolose dagli imballaggi e dai rifiuti di imballaggio)

#### **REGOLAMENTO R10**

(compatibilità elettromagnetica)

#### **GADSL**

(conformità alla lista delle sostanze dichiarabili del settore automobilistico)

#### **PAH**

(bando degli idrocarburi policiclici aromatici)

#### **CONFLICT MINERALS RULES**

(regole nate negli USA per scoraggiare l'uso di minerali preziosi - oro, tantalio, stagno, tungsteno e loro derivati - provenienti da aree in guerra)

**I colori RAL, riferiti ai prodotti contenuti in questo catalogo, sono puramente indicativi.  
Per eventuali abbinamenti o particolari necessità cromatiche contattare nostro Ufficio Commerciale**

All the products contained in this section complies with the following norms:

#### REGULATION 107/06

Special provisions for vehicles used for the carriage of passengers comprising more than eight seats in addition to the driver's seat and amending Directives 70/156/EEC, 97/27/EC and 2001/85/EC

#### UN ECE R118 and FMVSS302

Burning behaviour of materials used in interior construction of motor vehicles

#### DIRECTIVE 2000/53/EC ( and amendments:2008/33/EC

On the restriction of the use of certain heavy metals such as lead, cadmium, mercury and hexavalent chromium in the manufacturing process

#### DIRECTIVE 2002/95/EC

On the restriction of the use of certain heavy metals and brominated flame retardants such as polybrominated biphenils (PBB) and polybrominated diphenyls ethers (PBDE) in new electrical and electronic equipment

#### DIRECTIVE 1907/2006/EC - (REACH)

#### DIRECTIVE 2005/20/CE - (and amendments)

On the restriction of hazardous substances on packaging and packaging waste

#### REGULATION R10

Electric compatibility -EMC

#### GADSL

Conform to global automotive declarable substances list

#### PAH

Without polycyclic aromatic hydrocarbon

#### CONFLICT MINERALS RULES

Rules created to discourage the use of precious minerals (gold, tantalum, tin, tungsten and their derivatives) extracted in a conflict zone

**The RAL colors, referring to the products indicated on our catalogue, are purely indicatives.  
For eventual combinations or specific colors please contact our Sales Department**

**indice - index**

**Sistemi di apertura portelloni manuali / Manual doors opening systems**

**P.510M**

pag.H6



**Supporti e snodi per molle a gas - Supports and joints for gas springs**

**P.224**

pag.H8



**P.89**

pag.H9



**P.93**

pag.H10



**P.100**

pag.H11



**P.101**

pag.H12



**P.229**

pag.H13



**P.114**

pag.H14



**P.223**

pag.H15



## Sistemi di apertura portelloni pneumatici / Pneumatic doors opening systems

**P.510PN**

pag.H16



## Elementi per sistemi apertura pneumatici - Elements for pneumatic opening systems

**Kit chiusura centrale/  
Central closing kit**

pag.H18



**Elettrovalvola/  
Electrovalve**

pag.H19



**Kit lubrificazione/  
Lubrication kit**

pag.H20



## Sistemi di apertura portelloni elettrici / Electric doors opening systems

**P.520E**

pag.H22

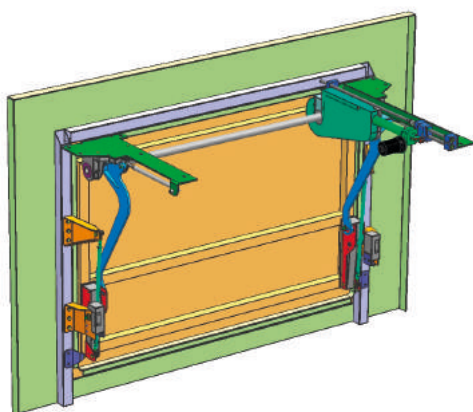

## P.510M

- Materiale - Material**  
Acciaio - Steel
- Colore - Color**  
Metallo - Metal
- Pezzi confezione - Package items**  
Secondo componenti - According to components
- Volume confezione - Package volume**  
Secondo componenti - According to components
- Peso confezione - Package weight**  
Secondo componenti - According to components
- Ricambi - Spare parts**  
Vedi sezione tecnica - See technical section
- Accessori - Accessories**  
Vedi sezione tecnica - See technical section
- Ciclo vita - Life cycle**  
100.000 azionamenti - actions
- Normative - Norms**  
pag. H2



### P.510 Kit base - Basic kit (2, 3, 4, 6, 8, 9)

| Cod.  |       |  |  |     |
|-------|-------|--|--|-----|
| 60242 | 6.500 |  |  | • 1 |

### P.510 Kit leveraggi - Levers kit (5, 7)

| Cod.  | H (mm)      |       |  |  |     |
|-------|-------------|-------|--|--|-----|
| 60252 | 750 ÷ 950   | 3.600 |  |  | • 1 |
| 60262 | 950 ÷ 1100  | 4.500 |  |  | • 1 |
| 60272 | 1100 ÷ 1300 | 5.000 |  |  | • 1 |
| 60282 | 1300 ÷ 1500 | 5.800 |  |  | • 1 |

### P.510 Molle a gas - Gas springs (1)

| Cod.  | Carico molla - Spring load (Kg) |     |  |  |     |
|-------|---------------------------------|-----|--|--|-----|
| 60342 | 40                              | 370 |  |  | • 1 |
| 60352 | 45                              | 370 |  |  | • 1 |
| 60952 | 50                              | 370 |  |  | • 1 |
| 60362 | 55                              | 370 |  |  | • 1 |
| 60372 | 60                              | 400 |  |  | • 1 |
| 60962 | 65                              | 400 |  |  | • 1 |
| 60382 | 70                              | 400 |  |  | • 1 |

- materiale disponibile a stock - material available on stock
- materiale non disponibile a stock - material not available on stock
- lotto minimo d'acquisto - minimum purchasing lot

I leveraggi devono essere scelti a seconda dell'altezza del portellone  
Levers to be chosen depending on the overall door height

H Altezza portellone - Overall door height

10 Possibile fornitura del portellone su richiesta. Per maggiori informazioni contattare l'ufficio commerciale di PRIMA Industries  
Possible supply of the door on request. For further information please contact PRIMA Industries sales department

La scelta delle molle deve essere fatta dal cliente in base all'applicazione. Per maggiori informazioni contattare l'ufficio commerciale di PRIMA Industries  
The choice of the gas springs must be made by the customer depending on the application. For further information please contact PRIMA Industries sales department

| Id. | Descrizione - Description  | Q.tà - Q.ty                |
|-----|--|----------------------------|
| (1) | Molla a gas (vedi Tab. 1) - Gas spring (see Tab. 1)  | 2/4 pz - pcs               |
| (2) | Supporto laterale ambidestro, con terminale sostegno tubo - Lateral support with self-aligning bearing         | 2 pz - pcs                 |
| (3) | Tubo in barra - Tube bars 1.500 mm   | 1 pz - pc                  |
| (4) | Staffa portellone attacco braccio di rotazione - Door side bracket for rotating arms                           | 2 pz - pcs                 |
| (5) | Bracci di rotazione (in funzione dell'altezza del portellone) - Rotating arms (depending on the door's height) | 2 pz - pcs                 |
| (6) | Staffa portellone attacco tirante - Door side bracket for tie rod  | 1 pz - pc R + 1 pz - pc L* |
| (7) | Tirante di registrazione - Tie rod   | 2 pz - pcs                 |
| (8) | Staffa telaio attacco tirante - Frame side bracket for tie rod   | 1 pz - pc R + 1 pz - pc L* |
| (9) | Staffa supporto molla a gas - Bracket for gas springs  | 2 pz - pcs                 |

\*R = Right/Destra \*L = Left/Sinistra



## P.510M

ClassicDOOR M è un sistema a pantografo manuale pratico ed economico per movimentare i portelloni degli autobus da turismo. Esso consiste in un tubo (3) che ruota su due boccole (2), mentre due bracci di spinta (5) aprono il portellone. Le due aste di registrazione (7) assicurano la stabilità durante la chiusura del pantografo, mentre alcune molle a gas (1) regolarizzano il portellone durante la chiusura e lo mantengono nella corretta posizione una volta chiuso.

In più le molle a gas contribuiscono a bilanciare e mantenere fluido il movimento di apertura. I supporti di fissaggio universali (8) sono provvisti di differenti punti di fissaggio per connettere i 4 kit di leveraggi disponibili, che devono essere scelti in base all'altezza del portellone (H).

Il kit include anche i supporti (4 e 6) per il fissaggio del portellone (regolabili in funzione delle dimensioni e forma del portellone) ed i supporti per il fissaggio delle molle a gas (9), che permettono un corretto posizionamento delle molle, in modo da garantire il perfetto funzionamento del sistema di apertura del portellone.

ClassicDOOR M pantograph system is a practical and economic method for the opening of coach luggage compartment doors. It consists of a tube (3) that rotates on two bearings (2), while two lever arms (5) open the door. The two rectifying shafts (7) ensure the stability during the closing of the pantograph, while some gas springs (1) brake the door during its closing and they maintain the door in the right position once it's closed.

Moreover the gas springs contribute to balance and keep smooth the opening movement. The universal fixing brackets include (8) different fixing points to connect the 4 available lever sets, that must be chosen conformly to the door height (H). The kit includes also the brackets (4 and 6) for the fixing to the hatch (to be adapted depending on the hatch dimensions and shape) and the gas spring supports (9), that permit a correct positioning of the springs, for a perfect working of the door opening system.

La fornitura e la scelta dei componenti del sistema vanno fatte rispettando i seguenti passi:

The supply and the choice of the components of the system must be done respecting the following steps:

### STEP 1

#### Dimensioni del portellone - Door's dimensions

Altezza portellone (H): tra 750 e 1.500 mm - Door's height (H): between 750 and 1.500 mm

Lunghezza portellone: nessun limite - Door's length: no limit

#### Peso del portellone - Door's weight

Peso consigliato: da 10 a 30 Kg max / Suggested weight: from 10 up to 30 Kg max

### STEP 2

Scelta del kit base - Choosing of the basic kit

Scelta del kit leveraggi - Choosing of the levers set

Scelta delle molle a gas - Choosing of the gas springs

Lo spazio laterale richiesto (LS) per l'apertura va da min. 400 mm per portelloni alti 750 mm fino a max. 630 mm per portelloni alti 1.500 mm



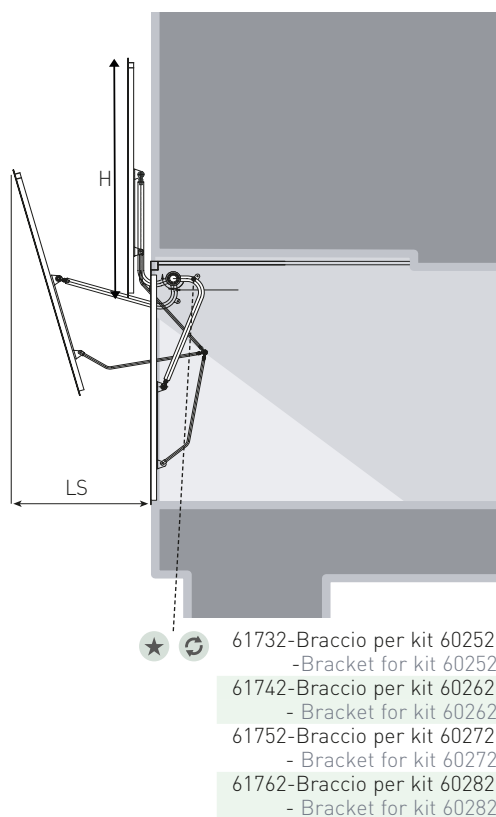





The lateral space (LS) needed for the opening is from min. 400 mm for doors 750 mm highs to max. 630 mm for doors 1.500 mm highs



La scelta delle molle a gas tra quelle disponibili verrà fatta di volta in volta in base alla specifica configurazione del portellone ed al suo peso

The choice of the available gas springs will be done everytime depending on the specific configuration of the door and on its weight

## P.224

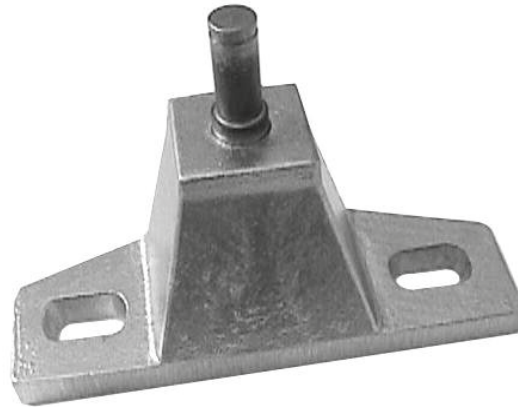

-  **Materiale - Material**  
Alluminio - Aluminium
-  **Colore - Color**  
Metallo - Metal
-  **Pezzi confezione - Package items**  
10 pezzi - pieces
-  **Volume confezione - Package volume**  
7 dm<sup>3</sup>
-  **Peso confezione - Package weight**  
1.460 g
-  **Ricambi - Spare parts**  
Vedi sezione tecnica - See technical section
-  **Accessori - Accessories**  
Vedi sezione tecnica - See technical section
-  **LEX Normative - Norms**  
pag. H2



### P.224

Cod.  
60168



-  materiale disponibile a stock - material available on stock
-  materiale non disponibile a stock - material not available on stock
-  lotto minimo d'acquisto - minimum purchasing lot





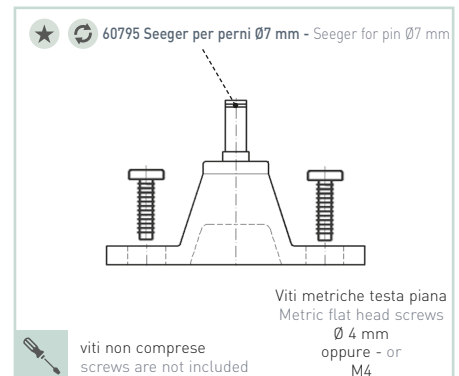
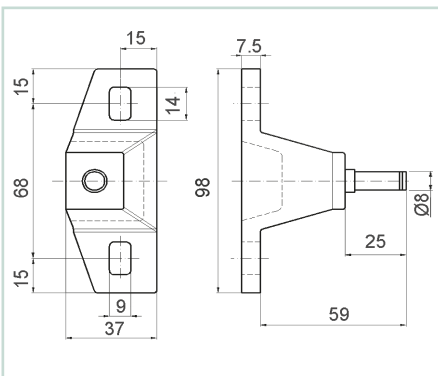



## Sezione tecnica - Technical section

### P.224





## P.89



-  **Materiale - Material**  
Poliammide - Polyamide
-  **Colore - Color**  
Grigio - Grey RAL 7042
-  **Pezzi confezione - Package items**  
100 pezzi - pieces
-  **Volume confezione - Package volume**  
2,1 dm<sup>3</sup>
-  **Peso confezione - Package weight**  
400 g
-  **Ricambi - Spare parts**  
Vedi sezione tecnica - See technical section
-  **Carico di rottura - Breakup load**  
Cursore - Slider = 1.000 N
-  **Temp. di esercizio - Working temp.**  
-10/+120 °C
-  **Normative - Norms**  
pag. H2



### P.89

Cod.  
66737









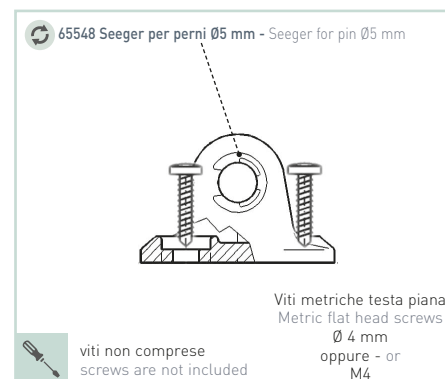
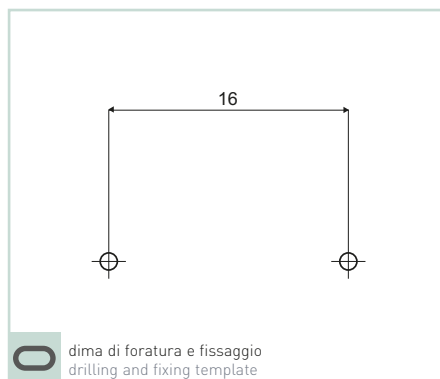
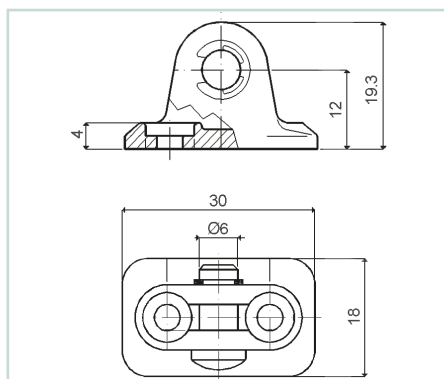

-  materiale disponibile a stock - material available on stock
-  materiale non disponibile a stock - material not available on stock
-  lotto minimo d'acquisto - minimum purchasing lot

## Sezione tecnica - Technical section

### P.89



## P.93

-  **Materiale - Material**  
Poliammide - Polyamide
-  **Colore - Color**  
Nero - Black
-  **Pezzi confezione - Package items**  
100 pezzi - pieces
-  **Volume confezione - Package volume**  
2,1 dm<sup>3</sup>
-  **Peso confezione - Package weight**  
1.300 g
-  **Ricambi - Spare parts**  
Vedi sezione tecnica - See technical section
-  **Carico di rottura - Breakup load**  
Cursore - Slider = 2.500 N
-  **Temp. di esercizio - Working temp.**  
-10/+120 °C
-  **Normative - Norms**  
pag. H2





### P.93

Cod.

69797









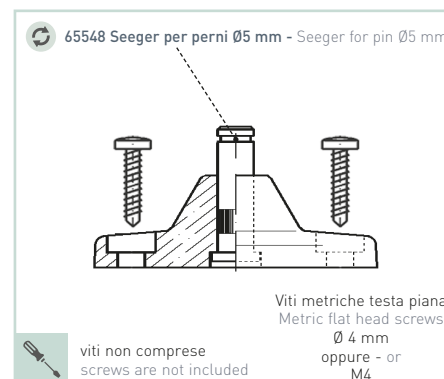
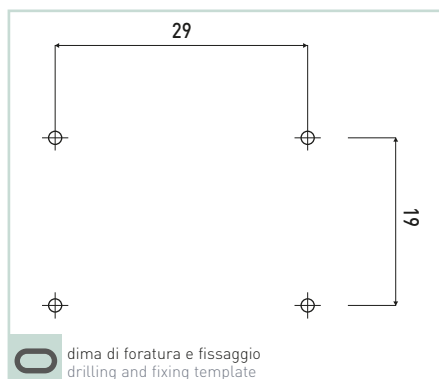
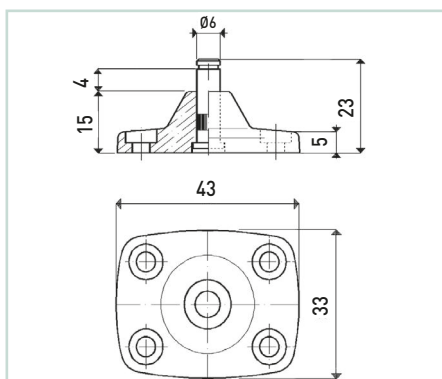

-  materiale disponibile a stock - material available on stock
-  materiale non disponibile a stock - material not available on stock
-  lotto minimo d'acquisto - minimum purchasing lot

## Sezione tecnica - Technical section

### P.93



## P.100

-  **Materiale - Material**  
Supporto in poliammide, perno in acciaio zincato - Polyamide support, zinc-plated steel pin
-  **Colore - Color**  
Nero - Black
-  **Pezzi confezione - Package items**  
100 pezzi - pieces
-  **Volume confezione - Package volume**  
7 dm<sup>3</sup>
-  **Peso confezione - Package weight**  
2.700 g
-  **Ricambi - Spare parts**  
Vedi sezione tecnica - See technical section
-  **Carico di rottura - Breakup load**  
Cursore - Slider = 4.500 N
-  **Temp. di esercizio - Working temp.**  
-10/+120 °C
-  **Normative - Norms**  
pag. H2





### P.100

Cod.

52100



-  materiale disponibile a stock - material available on stock
-  materiale non disponibile a stock - material not available on stock
-  lotto minimo d'acquisto - minimum purchasing lot

## Sezione tecnica - Technical section

### P.100

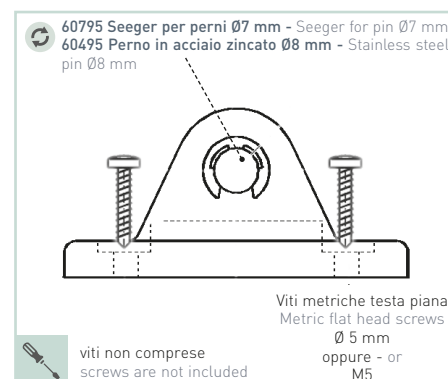
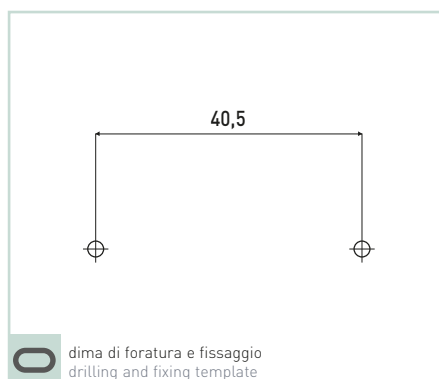
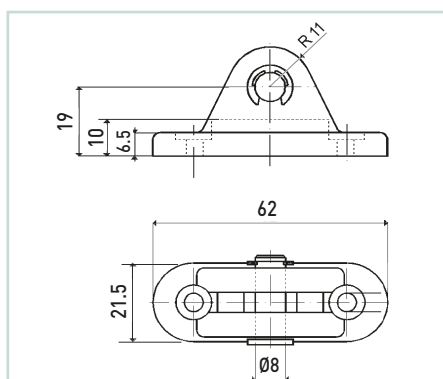

## P.101

- Materiale - Material**  
Supporto e distanziale in poliammide super tenace, perno in acciaio zincato - Very strong polyamide support and washer, zinc-plated steel pin
- Colore - Color**  
Nero - Black
- Pezzi confezione - Package items**  
100 pezzi - pieces
- Volume confezione - Package volume**  
Secondo codice - According to item code
- Peso confezione - Package weight**  
Secondo codice - According to item code
- Ricambi - Spare parts**  
Vedi sezione tecnica - See technical section
- Carico di rottura - Breakup load**  
Cursore - Slider = 4.500 N
- Temp. di esercizio - Working temp.**  
-10/+70 °C
- LEX Normative - Norms**  
pag. H2

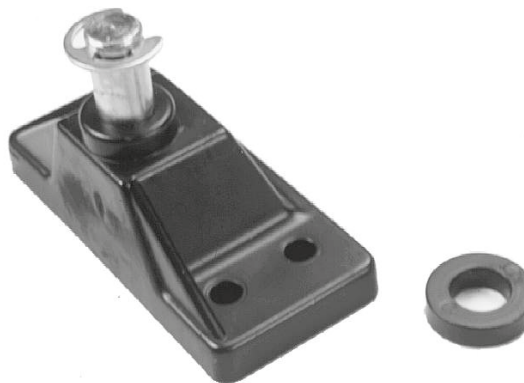

### P.101

| Cod.  | L mm | L1 mm |      |       |   |   |   |
|-------|------|-------|------|-------|---|---|---|
| 52110 | 40   | 11    | 7    | 4.010 | • | • | • |
| 65831 | 48   | 19    | 12,7 | 4.260 |   |   |   |

- materiale disponibile a stock - material available on stock
- materiale non disponibile a stock - material not available on stock
- lotto minimo d'acquisto - minimum purchasing lot

## Sezione tecnica - Technical section

### P.101

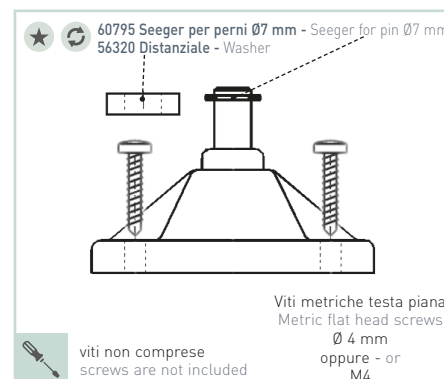
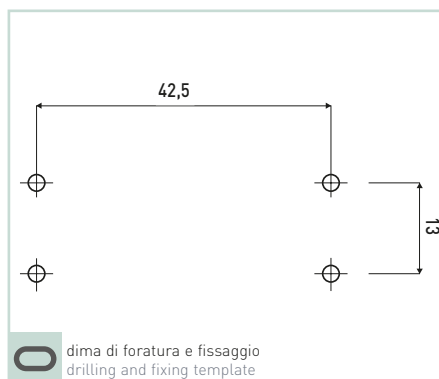
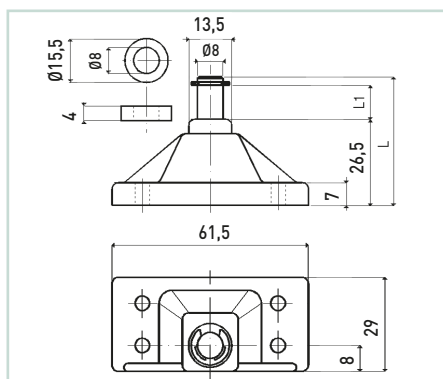

## P.229

- Materiale - Material**  
Acciaio - Steel
- Colore - Color**  
Metallo - Metal
- Pezzi confezione - Package items**  
10 pezzi - pieces
- Volume confezione - Package volume**  
0,86 dm<sup>3</sup>
- Peso confezione - Package weight**  
850 g
- Normative - Norms**  
pag. H2

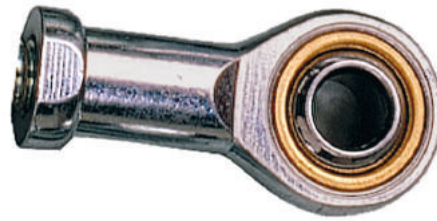

### P.229

Cod.

60178



- materiale disponibile a stock - material available on stock
- materiale non disponibile a stock - material not available on stock
- lotto minimo d'acquisto - minimum purchasing lot

## Sezione tecnica - Technical section

### P.229

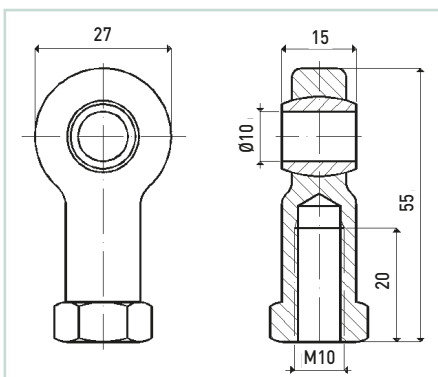

## P.114

- Materiale - Material**  
Acciaio zincato - Zinc-plated steel
- Colore - Color**  
Metallo - Metal
- Pezzi confezione - Package items**  
40 pezzi - pieces
- Volume confezione - Package volume**  
0,86 dm<sup>3</sup>
- Peso confezione - Package weight**  
400 g
- Normative - Norms**  
pag. H2



### P.114

Cod.

65517







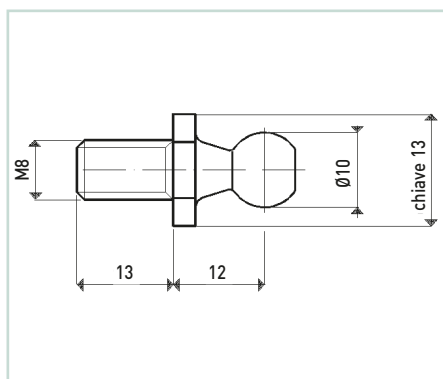

- materiale disponibile a stock - material available on stock
- materiale non disponibile a stock - material not available on stock
- lotto minimo d'acquisto - minimum purchasing lot

## Sezione tecnica - Technical section

### P.114







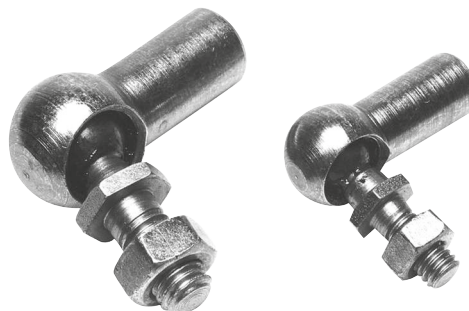









## P.223

-  **Materiale - Material**  
Acciaio zincato - Zinc-plated steel
-  **Colore - Color**  
Metallo - Metal
-  **Pezzi confezione - Package items**  
50 pezzi - pieces
-  **Volume confezione - Package volume**  
Secondo codice - According to item code
-  **Peso confezione - Package weight**  
Secondo codice - According to item code
-  **Normative - Norms**  
pag. H2



### P.223

| Cod.  | Tipo - Type |  |  |  |  |  |
|-------|-------------|---|---|---|---|---|
| 69807 | M6          | 0,86  | 2.500   |  |  |  |
| 69817 | M8          | 2,1   | 3.000   |  |  |  |

-  materiale disponibile a stock - material available on stock
-  materiale non disponibile a stock - material not available on stock
-  lotto minimo d'acquisto - minimum purchasing lot

## Sezione tecnica - Technical section

### P.223

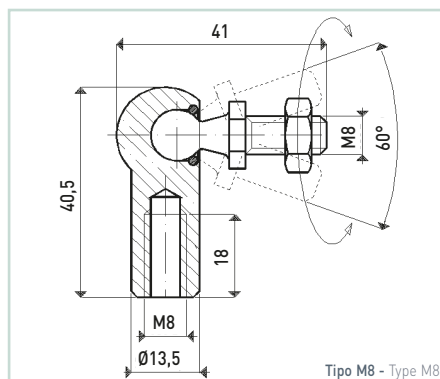
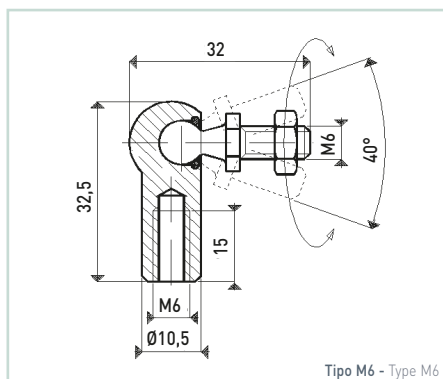



## P.510PN

- Materiale - Material**  
Acciaio - Steel
- Colore - Color**  
Metallo - Metal
- Pezzi confezione - Package items**  
Secondo componenti - According to components
- Volume confezione - Package volume**  
Secondo componenti - According to components
- Peso confezione - Package weight**  
Secondo componenti - According to components
- Ricambi - Spare parts**  
Vedi sezione tecnica - See technical section
- Accessori - Accessories**  
Vedi sezione tecnica - See technical section
- Ciclo vita - Life cycle**  
100.000 azionamenti - actions
- Normative - Norms**  
pag. H2

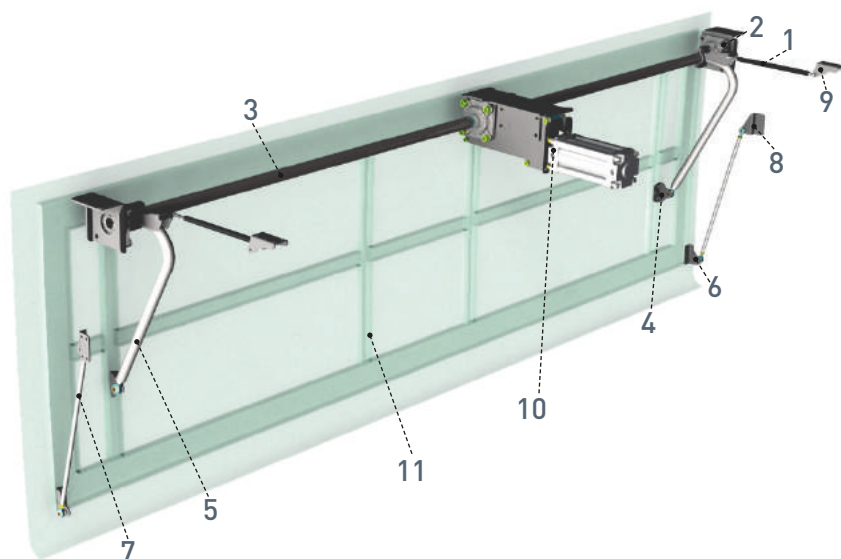

### P.510 Kit base - Basic kit (2, 3, 4, 6, 8, 9, 10)

| Cod.  | Cilindro/Cylinder |        |  |  |     |
|-------|-------------------|--------|--|--|-----|
| 67571 | Ø100 mm           | 30.000 |  |  | • 5 |

- materiale disponibile a stock - material available on stock
- materiale non disponibile a stock - material not available on stock
- lotto minimo d'acquisto - minimum purchasing lot

### P.510 Kit leveraggi - Levers kit (5, 7)

| Cod.  | H (mm)      |       |  |  |     |
|-------|-------------|-------|--|--|-----|
| 67611 | 800 ÷ 1000  | 4.700 |  |  | • 5 |
| 67621 | 1001 ÷ 1200 | 5.500 |  |  | • 5 |
| 67641 | 1201 ÷ 1500 | 6.300 |  |  | • 5 |

I leveraggi devono essere scelti a seconda dell'altezza del portellone  
Levers to be chosen depending on the overall door height

H Altezza portellone - Overall door height

11 Possibile fornitura del portellone su richiesta. Per maggiori informazioni contattare l'ufficio commerciale di PRIMA Industries  
Possible supply of the door on request. For further information please contact PRIMA Industries sales department

### P.510 Molle a gas - Gas springs (1)

| Cod.  | Carico molla - Spring load (Kg) |     |  |  |     |
|-------|---------------------------------|-----|--|--|-----|
| 60342 | 40                              | 370 |  |  | • 5 |
| 60352 | 45                              | 370 |  |  | • 5 |
| 60952 | 50                              | 370 |  |  | • 5 |
| 60362 | 55                              | 370 |  |  | • 5 |
| 60372 | 60                              | 400 |  |  | • 5 |
| 60962 | 65                              | 400 |  |  | • 5 |
| 60382 | 70                              | 400 |  |  | • 5 |

La scelta delle molle deve essere fatta dal cliente in base all'applicazione.  
Per maggiori informazioni contattare l'ufficio commerciale di PRIMA Industries  
The choice of the gas springs must be made by the customer depending on the application.  
For further information please contact PRIMA Industries sales department

|      |  |                            |
|------|--|----------------------------|
| (1)  | Molla a gas (vedi Tab. 1) - Gas spring (see Tab. 1)  | 2/4 pz - pcs               |
| (2)  | Supporto laterale ambidestro, con terminale sostegno tubo - Lateral support with self-aligning bearing         | 2 pz - pcs                 |
| (3)  | Tubo in barra - Tube bars 3.000 mm   | 1 pz - pc                  |
| (4)  | Staffa portellone attacco braccio di rotazione - Door side bracket for rotating arms                           | 2 pz - pcs                 |
| (5)  | Bracci di rotazione (in funzione dell'altezza del portellone) - Rotating arms (depending on the door's height) | 2 pz - pcs                 |
| (6)  | Staffa portellone attacco tirante - Door side bracket for tie rod  | 1 pz - pc R + 1 pz - pc L* |
| (7)  | Tirante di registrazione - Tie rod   | 2 pz - pcs                 |
| (8)  | Staffa telaio attacco tirante - Frame side bracket for tie rod   | 1 pz - pc R + 1 pz - pc L* |
| (9)  | Staffa supporto molla a gas - Bracket for gas springs  | 2 pz - pcs                 |
| (10) | Assieme gruppo riduttore - Gear boxes  | 1 pz - pc                  |

\*R = Right/Destra \*L = Left/Sinistra

## P.510PN

ClassicDOOR PN è un pratico ed economico metodo per la movimentazione automatica dei portelloni degli autobus da turismo. Esso consiste in un cilindro pneumatico che muove un riduttore (10), il quale ruota su un tubo (3) su cui sono fissati due bracci di rotazione (5) che aprono il portellone.

Le due aste di registrazione (7) assicurano la stabilità durante la chiusura e l'apertura del pantografo, mentre alcune molle a gas (1) regolarizzano il portellone durante la chiusura e lo mantengono nella posizione corretta. In più le molle a gas contribuiscono a bilanciare e mantenere fluido il movimento di apertura. Il sistema comprende anche le staffe (4 e 6) per il fissaggio del portellone e le staffe di supporto delle molle a gas (9).

ClassicDOOR PN is a practical and economic method for the automatic moving of coach luggage compartment doors. It consists in a pneumatic cylinder moving a gear boxes (10), which rotates on a tube (3) where two lever arms are fitted (5) and open the door. The two rectifying shafts (7) ensure the stability during the closing and opening of the pantograph, while some gas springs (1) brake the door during its closing and they maintain the door in the right position.

Moreover the gas springs contribute to balance and keep smooth the opening movement. The system includes also the brackets (4 and 6) for fitting the door and the brackets for the support of the gas springs (9).

La fornitura e la scelta dei componenti del sistema vanno fatte rispettando i seguenti passi:  
The supply and the choice of the components of the system must be done respecting the following steps:

### STEP 1

#### Dimensioni e peso del portellone - Door's dimensions and weight

Altezza portellone (H): tra 800 e 1.500 mm - Door's height (H): between 800 and 1.500 mm

Lunghezza portellone: nessun limite - Door's length: no limit

Peso consigliato: da 30 a 80 Kg max / Suggested weight: from 30 up to 80 Kg max

Pressione aria disponibile per il sistema (bar) - Available air pressure for the system (bar)

### STEP 2

Scelta del kit base - Choosing of the basic kit

Scelta del kit leveraggi - Choosing of the levers set

Scelta delle molle a gas - Choosing of the gas springs

Eventuale scelta del kit di chiusura centrale - Possible choosing of the central closing kit

Eventuale scelta valvola pneumatica o elettrovalvola - Possible choosing of the pneumatic valve or electrovalve

Eventuale scelta del kit di lubrificazione - Possible choosing of the lubrication kit

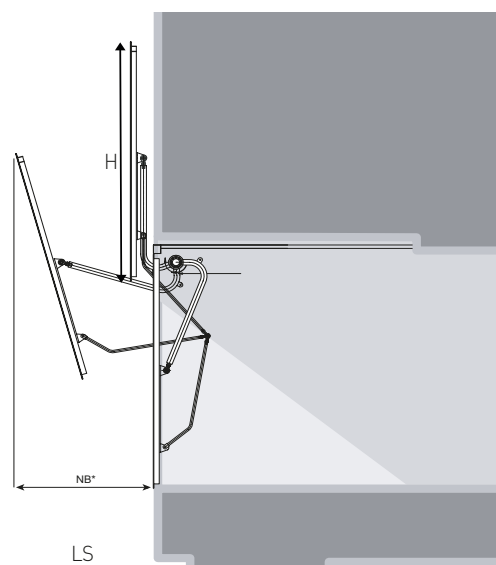

- ★ 69741-Braccio per kit 67611
- ♻️ 69751-Braccio per kit 67621
- 69761-Braccio per kit 67641

#### ■ Vantaggi - Advantages

- a) Spazio laterale richiesto (LS) per l'apertura da min 425 mm per portelloni alti 800 mm fino a max. 630 mm per portelloni alti 1.500 mm
- b) Possibilità, in caso di emergenza (se la pressione d'aria non è sufficiente), di movimentare manualmente il portellone
- c) Possibilità di montare il gruppo cilindro pneumatico nella zona centrale oppure su un lato del compartimento del portellone e di movimentare più portelloni (adiacenti fra loro) contemporaneamente, utilizzando un singolo cilindro pneumatico

- a) Lateral space (LS) needed for the opening is from a min of 425 mm for doors 800 mm highs to a max of 630 mm for doors 1.500 mm highs
- b) Possibility, in case of emergency (if the air pressure isn't available), to raise/lower manually the door
- c) Possibility to fix the pneumatic cylinder/gear boxes in the middle side or on the lateral side of the luggage compartment door and to move simultaneously more than one neighbouring doors, using a single thrust cylinder

|                                  |       | Altezza portellone/Door's height |                        |                        |
|----------------------------------|-------|----------------------------------|------------------------|------------------------|
|                                  |       | 800 – 1000 mm                    | 1001 – 1.200 mm        | 1.201 – 1.500 mm       |
| Peso portellone<br>Door's weight | 55 Kg | 2 x 70 Kg (Cod. 60382)           | 4 x 40 Kg (Cod. 60342) | 4 x 45 Kg (Cod. 60352) |
|                                  | 60 Kg | 2 x 70 Kg (Cod. 60382)           | 4 x 45 Kg (Cod. 60352) | 4 x 50 Kg (Cod. 60952) |
|                                  | 65 Kg | 4 x 40 Kg (Cod. 60342)           | 4 x 50 Kg (Cod. 60952) | 4 x 55 Kg (Cod. 60362) |
|                                  | 70 Kg | 4 x 40 Kg (Cod. 60342)           | 4 x 50 Kg (Cod. 60952) | 4 x 60 Kg (Cod. 60372) |
|                                  | 75 Kg | 4 x 45 Kg (Cod. 60352)           | 4 x 55 Kg (Cod. 60362) | 4 x 65 Kg (Cod. 60962) |
|                                  | 80 Kg | 4 x 45 Kg (Cod. 60352)           | 4 x 60 Kg (Cod. 60372) | 4 x 70 Kg (Cod. 60382) |

Tab. 1 I dati riportati nella tabella sono indicativi - The data in the table are indicative, to be checked on the field

# Kit chiusura centrale - Central closing kit

## P.510PN

- Materiale - Material**  
Alluminio e acciaio - Aluminium and steel
- Colore - Color**  
Metallo - Metal
- Pezzi confezione - Package items**  
1 pezzo - piece
- Volume confezione - Package volume**  
7 dm<sup>3</sup>
- Peso confezione - Package weight**  
1.550 g
- Normative - Norms**  
pag. H2

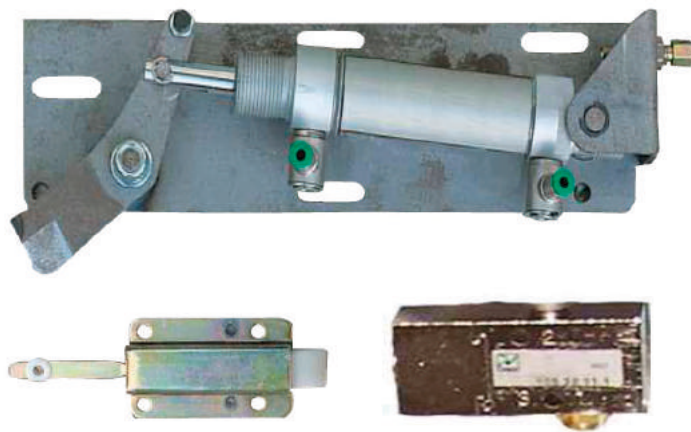

### P.510PN

Cod.

69491



• 1





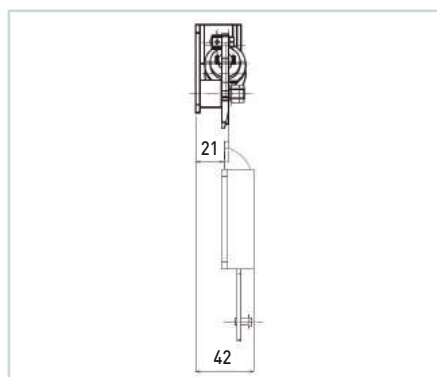
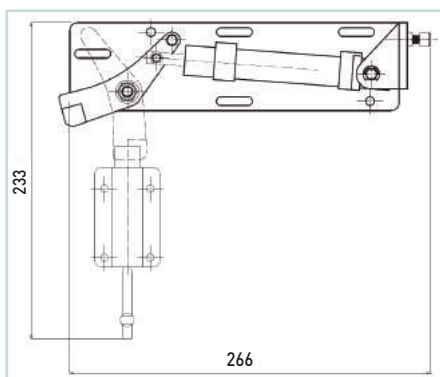

- materiale disponibile a stock - material available on stock
- materiale non disponibile a stock - material not available on stock
- lotto minimo d'acquisto - minimum purchasing lot

## Sezione tecnica - Technical section

### P.510PN









## P.510PN

-  **Materiale - Material**  
Compound materiali vari - Various materials compound
-  **Colore - Color**  
Metallo - Metal
-  **Pezzi confezione - Package items**  
1 pezzo - piece
-  **Volume confezione - Package volume**  
2 dm<sup>3</sup>
-  **Peso confezione - Package weight**  
400 g
-  **Normative - Norms**  
pag. H2



### P.510PN

| Cod.  |    |  |  |  |
|-------|----|---|---|---|
| 68561 | 12 |   |   | • 1   |
| 68671 | 24 |   |   | • 1   |

-  materiale disponibile a stock - material available on stock
-  materiale non disponibile a stock - material not available on stock
-  lotto minimo d'acquisto - minimum purchasing lot

## Sezione tecnica - Technical section

### P.510PN

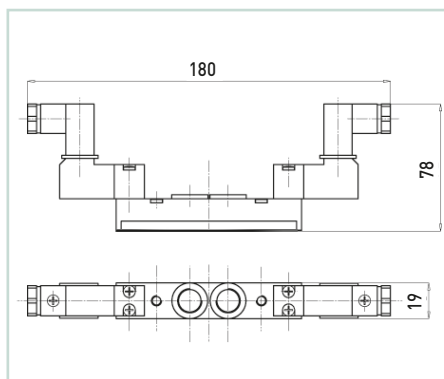

#### ★ P.117

| Cod.  | ØExt (mm) | ØInt (mm) | L (m) |
|-------|-----------|-----------|-------|
| 64667 | 4         | 2         | 25    |
| 69247 | 6         | 4         | 25    |
| 64677 | 8         | 6         | 25    |
| 67547 | 10        | 8         | 25    |



#### ★ 69701 Valvola pneumatica per pilotaggio salita/discisa del portellone Pneumatic valve for door raising/lowering command



Nel caso in cui si intenda utilizzare un comando pneumatico anziché un interruttore elettrico per l'apertura e chiusura del portellone, è necessario utilizzare la valvola pneumatica al posto dell'elettrovalvola. In case you wish to use a pneumatic device instead of an electric switch for the door's opening and closing, it's needed to use the pneumatic valve instead of the electrovalve.

# Kit lubrificazione - Lubrication kit

## P.510PN

**Materiale - Material**  
Compound materiali vari - Various materials compund

**Colore - Color**  
Metallo - Metal

**Pezzi confezione - Package items**  
1 pezzo - piece

**Volume confezione - Package volume**  
2,11 dm<sup>3</sup>

**Peso confezione - Package weight**  
1.500 g

**Normative - Norms**  
pag. H2



### P.510PN

Cod.

67221



• 1

◀ materiale disponibile a stock - material available on stock

✘ materiale non disponibile a stock - material not available on stock

Min lotto minimo d'acquisto - minimum purchasing lot

## Sezione tecnica - Technical section

### P.510PN

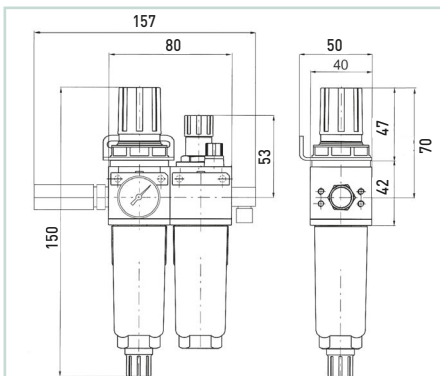

1-67031 Filtro + regolatore di pressione - Filter + air regulator  
2-67041 Manometro - Manometer  
3-67051 Lubrificatore aria - Air lubricator

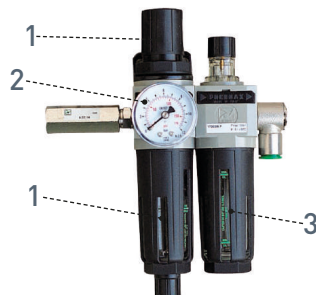







### ★ P.117

| Cod.  | ØExt (mm) | ØInt (mm) | L (m) |
|-------|-----------|-----------|-------|
| 64667 | 4         | 2         | 25    |
| 69247 | 6         | 4         | 25    |
| 64677 | 8         | 6         | 25    |
| 67547 | 10        | 8         | 25    |





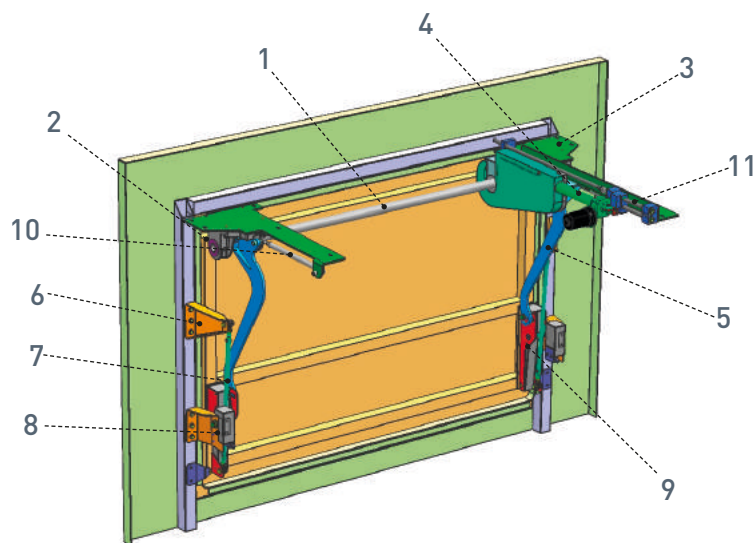

## P.520E

-  **Materiale - Material**  
Acciaio + Poliammide fibra vetro - Steel + glass fibre polyamide
-  **Colore - Color**  
Metallo - Metal
-  **Pezzi confezione - Package items**  
Secondo componenti - According to components
-  **Volume confezione - Package volume**  
Secondo componenti - According to components
-  **Peso confezione - Package weight**  
Secondo componenti - According to components
-  **Ricambi - Spare parts**  
Vedi sezione tecnica - See technical section
-  **Ciclo vita - Life cycle**  
100.000 azionamenti - actions
-  **LEX Normative - Norms**  
pag. H2





### P.520 Kits

|               | L < 2.000 mm<br>W < 50 Kg | 2.000 < L < 3.000 mm<br>W < 50 Kg | 3.000 < L < 4.500 mm<br>W > 50 Kg |    |
|---------------|---------------------------|-----------------------------------|-----------------------------------|--|
| Cod.<br>61303 | •                         |                                   |                                   | •  |

Tab. 1

L = lunghezza portellone - door length

W = peso portellone - door weight

-  materiale disponibile a stock - material available on stock
-  materiale non disponibile a stock - material not available on stock
-  lotto minimo d'acquisto - minimum purchasing lot

| Id.  | Descrizione - Description   |
|------|---|
| (1)  | Tubo con ruota dentata - Tube with toothed whell                                  |
| (2)  | Supporti laterali con boccole - Lateral supports with bushings                    |
| (3)  | Staffa fissaggio attuatore elettrico - Side bracket for electric actuator fitting |
| (4)  | Attuatore lineare elettrico - Electric linear actuator                            |
| (5)  | Bracci di rotazione - Rotating arms   |
| (6)  | Staffe telaio attacco tiranti - Frame side brackets for tie rods                  |
| (7)  | Tiranti di registrazione - Tie rods   |
| (8)  | Staffe telaio con perno di chiusura - Frame brackets with locking pin             |
| (9)  | Staffe portellone con ganci di chiusura - Tailgate brackets with locking hooks    |
| (10) | Molla a gas - Gas spring  |
| (11) | Apertura di emergenza - Emergency opening   |



## P.520E

E-door è un sistema a pantografo elettrico pratico ed economico per movimentare i portelloni degli autobus da turismo. Esso consiste in un tubo (1) che ruota su due boccole (2), mentre due bracci di spinta (5) aprono il portellone grazie all'azione di un potente attuatore lineare (4). Le due aste di registrazione (7) assicurano la stabilità durante la chiusura del pantografo, mentre la molla a gas (10) regolarizza il portellone durante la chiusura.

Varie staffe di fissaggio universali permettono la connessione dei tiranti e bracci di rotazione al portellone e al telaio del bus.

La chiusura del portellone è eseguita da due ganci movimentati meccanicamente dai due bracci di rotazione (5).

Il sistema prevede un meccanismo per l'apertura manuale d'emergenza del portellone (11).

Tutta la parte elettronica viene gestita da apposita centralina, inclusa in ogni kit.

Il portellone può essere movimentato esclusivamente con il freno di stazionamento inserito.

E-door is an electric pantograph system, practical and economic, to move the doors of the coaches. It consists in a tube (1) rotating on two bushes (2), while two rotation arms (5) open the door thanks to the job of a powerful linear actuator (4). The two adjusting rods (7) assure the stability while the pantograph is closing, while the gas spring (10) adjusts the door during its closing.

Various standard brackets allow the connection of the rods and rotation arms to the door and the frame of the bus.

The door is closed by two hooks mechanically moved by the two rotation arms (5).

The system includes a mechanism for manually opening the tailgate emergency (11).

All the electronic part is managed from a specific control unit, included in every kit.

The tailgate can only be moved with the parking brake applied.

La fornitura e la scelta dei kits vanno fatte rispettando i seguenti passi:

The supply and the choice of the components of the system must be done respecting the following steps:

### STEP 1

#### Dimensioni del portellone - Door's dimensions

Verificare la lunghezza e il peso del/i portellone/i, in accordo con la classificazione evidenziata in Tab. 1

Check the length and weight of the door/s, according to the classification remarked on Tab. 1

### STEP 2

Configurazione del bus e numero dei portelloni - Bus configuration and number of the doors

Lo spazio laterale richiesto per l'apertura è pari a 525 mm -The lateral space needed for the opening is 525 mm

