

24V C.C. - D.C.

VA01-BP78/LL-89A

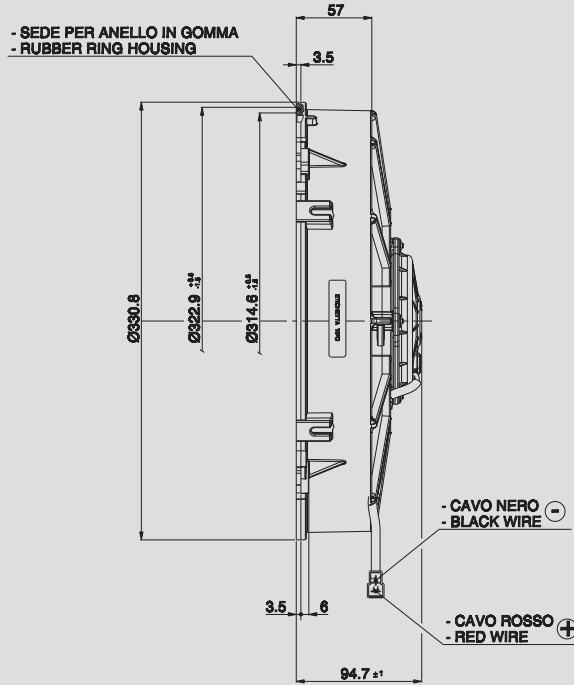
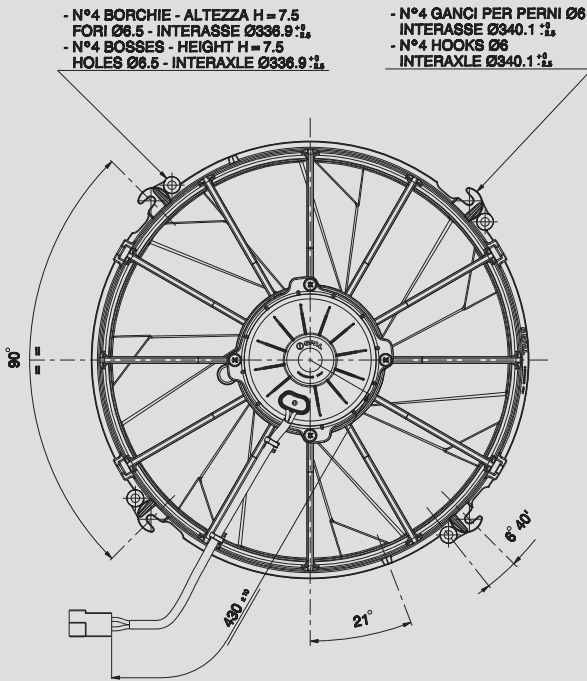

AMP connector Code 180908
 AMP terminal Code 42098-2
 Suggested mounting torque: 3(+1/-0) Nm with screw M5
 Weight 2,50 Kg. approx.

Connettore AMP Cod. 180908
 Terminali AMP Cod. 42098-2
 Coppia di serraggio consigliata: 3(+1/-0) Nm con vite M5
 Peso 2,50 Kg. circa

Ø 305 mm

Ø 12"

suction / aspirante

Static pressure Pressione statica mm H ₂ O	Airflow Portata m ³ /h	Current input Corrente assorbita A	Airflow Portata CFM	Static pressure Pressione statica inH ₂ O
0	2400	6,3	1416	0
5	2230	6,8	1316	0,2
10	2050	7,6	1210	0,4
15	1840	8,2	1086	0,6
20	1620	8,7	956	0,8
25	1340	9,2	791	1
30	990	9,8	584	1,2
35	730	10,4	431	1,4
40	460	10,9	271	1,6
45	220	11,3	130	1,8
50	0	12,0	0	2

PRODUCT FEATURES
CARATTERISTICHE PRODOTTO

Waterproof motor, IP 68 Motore chiuso, IP 68	✓
Low noise / Bassa rumorosità	✓
Long life / Lunga durata	✓
VLL version* / Versione VLL*	✓
Waterproof connector Connettori a tenuta stagna	✓
Accessories: all the fixing kits Accessori: tutti i kit di fissaggio	✓

* for OEM applications only.
 * per applicazioni OEM

✓ = Standard feature
 Caratteristiche standard

✓ = Available upon request
 Disponibile su richiesta

Test voltage 26 V. D.C. - Tensione di prova 26 V. c.c.