

12V C.C. - D.C.

VA17-AP70/LL-51A
VA17-AP70/LL-51S

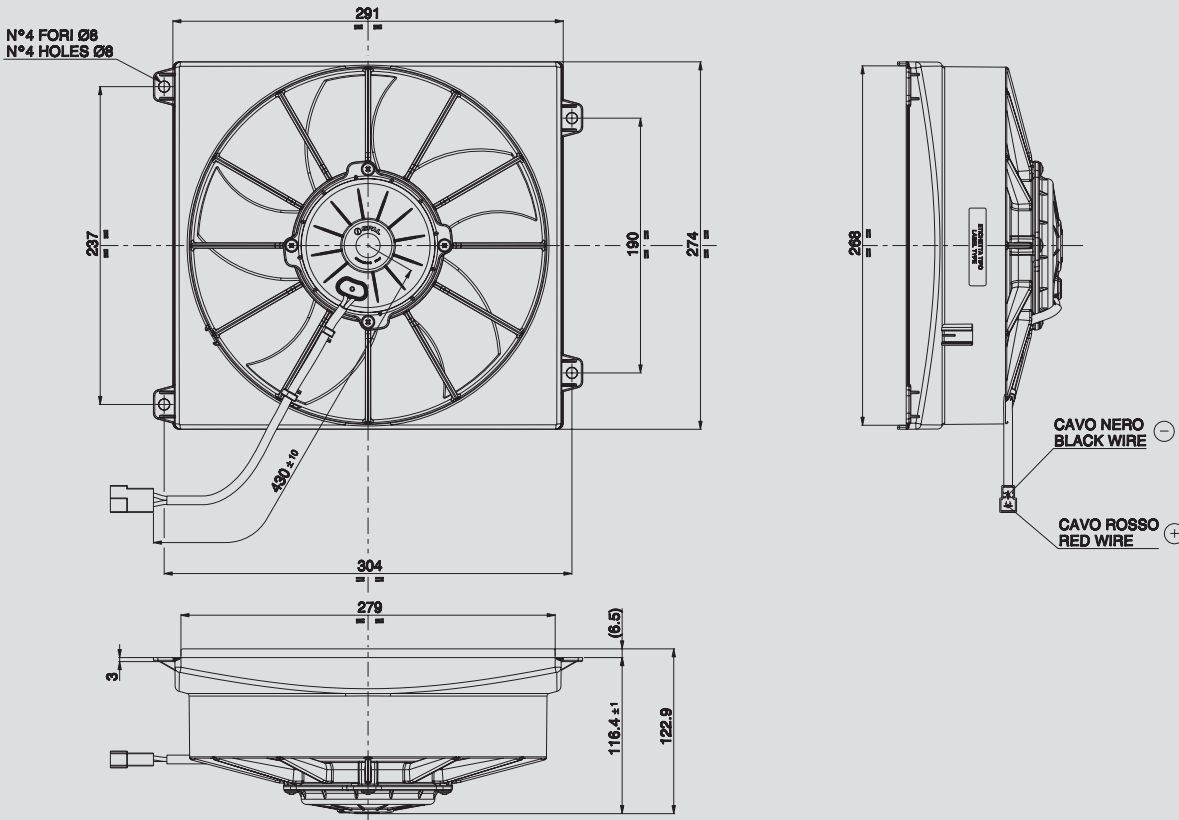

AMP connector Code 180908
AMP terminal Code 42098-2
Suggested mounting torque: 3(+1/-0) Nm with screw M5
Weight 2,37 Kg. approx.

Connettore AMP Cod. 180908
Terminali AMP Cod. 42098-2
Coppia di serraggio consigliata: 3(+1/-0) Nm con vite M5
Peso 2,37 Kg. circa

Ø 255 mm

Ø 10"

suction / aspirante

blowing / soffiante

PRODUCT FEATURES
CARATTERISTICHE PRODOTTO

Static pressure Pressione statica mm H ₂ O	suction / aspirante			blowing / soffiante			Static pressure Pressione statica in H ₂ O
	Airflow Portata m ³ /h	Current input Corrente assorbita A	Airflow Portata CFM	Airflow Portata m ³ /h	Current input Corrente assorbita A	Airflow Portata CFM	
0	1830	10,3	1080	1730	9,7	1021	0
5	1630	11,0	962	1530	10,4	903	0,2
10	1430	11,5	844	1320	11,0	779	0,4
15	970	11,1	572	1040	11,4	614	0,6
20	690	11,7	407	710	11,7	419	0,8
25	540	11,8	319	340	11,7	201	1,0
30	360	12,0	212	90	12,4	53	1,2
35	180	12,7	106	0	13,3	0	1,4
40	60	14,0	35				1,6
45	0	14,8	0				1,8

Waterproof motor, IP 68 Motore chiuso, IP 68	✓
Low noise / Bassa rumorosità	✓
Long life / Lunga durata	✓
VLL version* / Versione VLL*	✓
Waterproof connector Connettori a tenuta stagna	✓

* for OEM applications only.
* per applicazioni OEM

✓ = Standard feature
Caratteristiche standard

✓ = Available upon request
Disponibile su richiesta

Test voltage 13 V. d.c. - Tensione di prova 13 V. c.c.