

**24V C.C. - D.C.**

**VA37-B100-46A  
VA37-B100-46S**

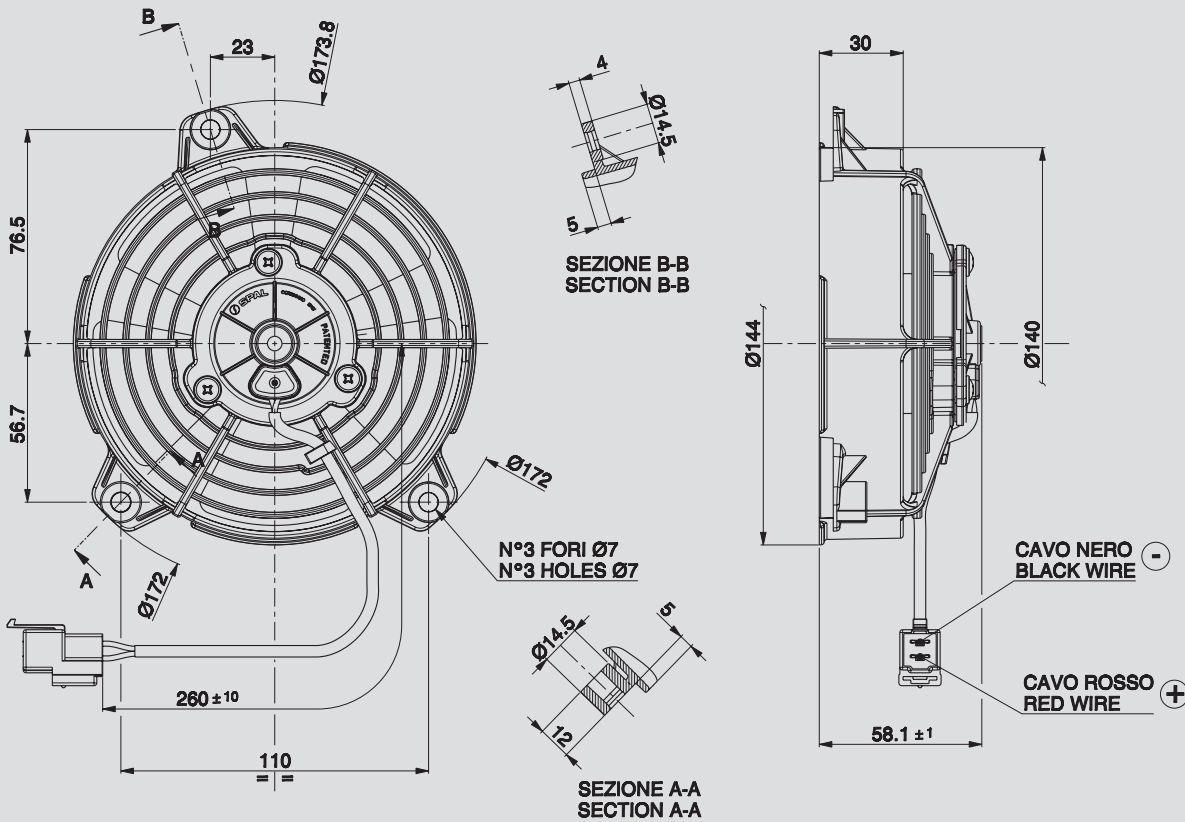

Connector SUMITOMO Code 6010-2802  
SUMITOMO terminal Code 1800-2093  
Suggested mounting torque: 3(+1/-0) Nm with screw M5  
Weight 0,42 Kg. approx.

Connettore SUMITOMO Cod. 6010-2802  
Terminali SUMITOMO Cod. 1800-2093  
Coppia di serraggio consigliata: 3(+1/-0) Nm con vite M5  
Peso 0,42 Kg. circa

Ø 130 mm

Ø 5,2"

suction / aspirante

blowing / soffiante

PRODUCT FEATURES  
CARATTERISTICHE PRODOTTO

Static pressure Pressione statica mm H <sub>2</sub> O	suction / aspirante			blowing / soffiante			Static pressure Pressione statica inH <sub>2</sub> O
	Airflow Portata m <sup>3</sup> /h	Current input Corrente assorbita A	Airflow Portata CFM	Airflow Portata m <sup>3</sup> /h	Current input Corrente assorbita A	Airflow Portata CFM	
0	400	1,7	236	380	1,5	224	0
2,5	380	1,6	224	350	1,5	207	0,1
5	340	1,6	201	320	1,5	189	0,2
7,5	320	1,7	189	260	1,6	153	0,3
10	260	1,8	153	200	1,6	118	0,4
12,5	190	1,7	112	160	1,8	94	0,5
15	140	1,8	83	120	1,8	71	0,6
17,5	80	1,9	47	100	1,9	59	0,7
20	60	2,0	35	70	1,9	41	0,8
22,5	20	2,0	12	20	2,1	12	0,9
25	0	2,0	0	0	2,1	0	1

Waterproof motor, IP 68  
Motore chiuso, IP 68



Waterproof connector  
Connettori a tenuta stagna



✓ = Standard feature  
Caratteristiche standard

✓ = Available upon request  
Disponibile su richiesta

Test voltage 26 V. D.C. - Tensione di prova 26 V. c.c.